

G2 DATA SHEET



CONTENTS

1	PRODUCT OVERVIEW.....	1
1.1	Product Features.....	1
1.2	Applications.....	1
1.3	Installation and Dimensions.....	2
2	SPECIFICATIONS.....	2
2.1	Product Parameter.....	2
2.2	Electrical Parameter.....	3
2.3	Interface Definition.....	3
2.4	Data Communication.....	4
2.5	Optical Characteristic.....	4
2.6	Polar Coordinate System Definition.....	5
2.7	Others.....	5
3	REVISE.....	6

1 PRODUCT OVERVIEW

YDLIDAR G2 is a 360° 2D LiDAR(hereinafter referred to as G2) developed by YDLIDAR team. Based on the principle of Triangulation, it is equipped with related optics, electricity, and algorithm design to achieve high-frequency and high-precision distance measurement. The mechanical structure rotates 360° to continuously output the angle information as well as the point cloud data of the scanning environment while ranging.

1.1 Product Features

- 360° scan ranging
- High accuracy, stable performance
- Wide measuring range
- Strong resistance to ambient light interference
- Industrial grade brushless motor drive, stable performance
- Class I eye safety
- 360° omnidirectional scanning and 5-12Hz frequency
- Using optical and magnetic fusion technology to realize wireless communication and wireless power supply
- High-speed ranging, up to 5000Hz frequency

1.2 Applications

- Robot navigation and obstacle avoidance
- Industrial automation
- Regional security
- Intelligent transportation
- Environmental scanning and 3D reconstruction
- Digital multimedia interaction
- Robot ROS teaching and research

1.3 Installation and Dimensions

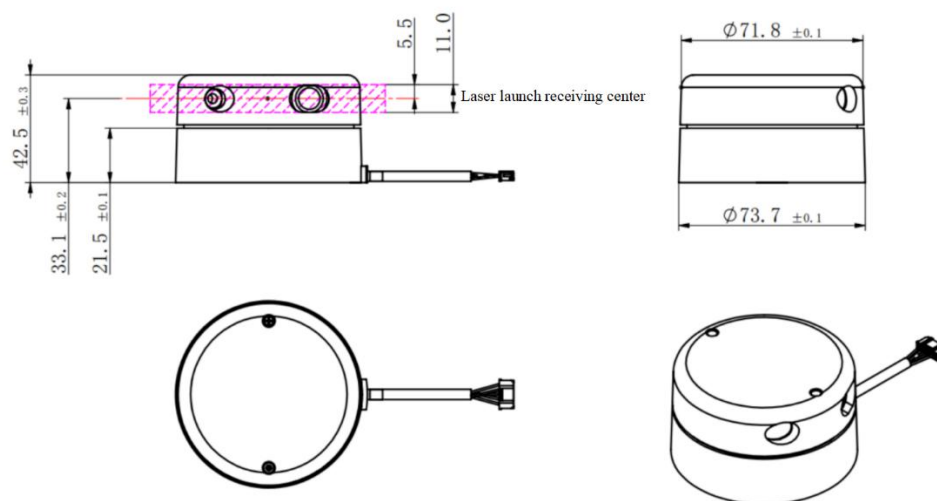

FIG 1 YDLIDAR G2 INSTALLATION&MECHANICAL SIZE

2 SPECIFICATIONS

2.1 Product Parameter

CHART 1 YDLIDAR G2 PRODUCT PARAMETER

Item	Min	Typical	Max	Unit	Remarks
Ranging frequency	/	5000	/	Hz	Ranging 5000 times per second
Motor frequency	5	7	12	Hz	Software control, Factory setting 7Hz
Ranging distance	0.12	/	12	m	80% Reflectivity
Field of view	/	0-360	/	°	/
Systematic Error	/	2	/	cm	Range ≤ 1m
Statistical Error	/	2.0%	/	/	1m < Range ≤ 8m
Luminous intensity range	0	/	1023	/	laser intensity
Laser inclination	0.25	1	1.75	°	Laser pitch angle
Angle resolution	0.36 (Frequency @5Hz)	0.504 (Frequency @7Hz)	0.864 (Frequency @12Hz)	°	/

Note1: The range and relative accuracy in the above table are factory values, statistical error changes with the actual distance value;

Note2: In the above table, the relative error value represents the accuracy of the radar measurement, Statistical Error = (Ranging distance - actual distance)/ actual distance * 100%. LiDAR is a precision equipment, which needs to be protected during use. In the use scenarios of high temperature, high and low temperature or strong vibration, the parameter index of relative error will be relatively larger, and the error may exceed the than Typical value.

2.2 Electrical Parameter

CHART 2 YDLIDAR G2 ELECTRICAL PARAMETER

Item	Min	Typical	Max	Unit	Remarks
Supply voltage	4.8	5.0	5.2	V	Excessive voltage might damage the Lidar while low affect normal performance
Startup current	1000	/	/	mA	Instantaneous peak current at start-up
Sleeping current	/	/	50	mA	System sleep, motor stops
Working current	/	350	500	mA	System work, motor speed=7Hz

2.3 Interface Definition

G2 provides PH2.0-5P female connector to realize power and data communication function.

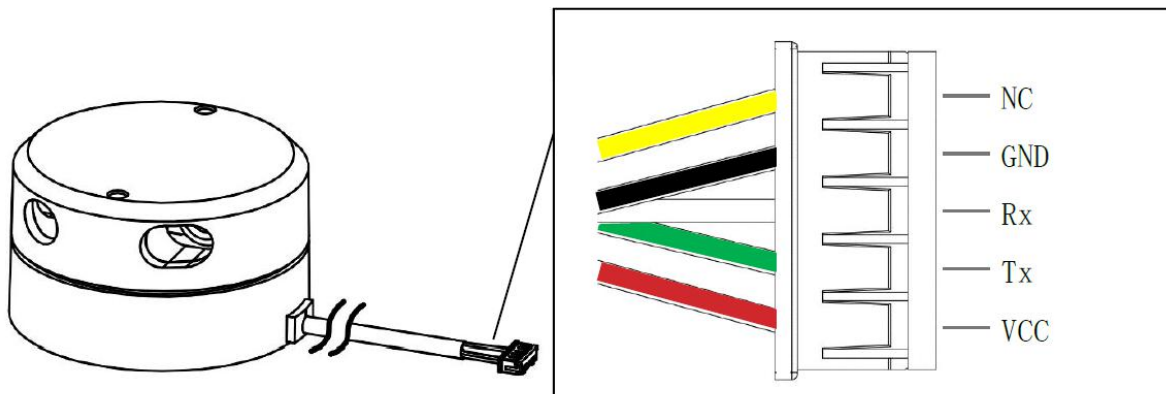

FIG 2 YDLIDAR G2 INTERFACES

CHART 3 YDLIDAR G2 INTERFACE DEFINITION

Pin	Type	Description	Defaults	Range	Remarks
VCC	Power Supply	Positive	5V	4.8V-5.2V	/
Tx	Output	System serial port output	/	/	Data stream: Lidar→Peripherals
Rx	Input	System serial port Input	/	/	Data stream: Peripherals→Lidar
GND	Power Supply	Negative	0V	0V	/
NC	Reserve	Reserved pin	/	/	/

2.4 Data Communication

With a 3.3V level serial port (UART), users can connect the external system and the product through the physical interface. After that, you can obtain the real-time scanned point cloud data, device information as well as device status. The communication protocol of parameters are as follows:

CHART 4 YDLIDAR G2 SERIAL SPECIFICATION

Item	Min	Typical	Max	Unit	Remarks
Baud rate	/	230400	/	bps	8-bit data bit, 1 stop bit, no parity
High Signal Level	2.4	3.3	3.5	V	/
Low signal Level	0	0.3	0.6	V	/

2.5 Optical Characteristic

G2 uses an infrared laser that meets FDA Class I eye safety standards. The laser and optical lens finish the transmission and reception of the laser signal to achieve high-frequency ranging while working. To ensure system ranging performance, please keep the laser and optical lens clean. The detailed optical parameters are as follows:

CHART 5 YDLIDAR G2 LASER OPTICAL PARAMETERS

Item	Min	Typical	Max	Unit	Remarks
Laser Wavelength	775	792	800	nm	Infrared band
Laser Power	/	3.5	6	mw	Average power
FDA	 Class I				

2.6 Polar Coordinate System Definition

In order to facilitate secondary development, G2 internally defines a polar coordinate system. The polar coordinates of the system take the center of the rotating core of G2 as the pole, and the specified Angle is positive clockwise (top view). The zero Angle is located in the direction of the outlet of the G2 PH2.0-5P interface line. Due to individual differences, there is a deviation of $\pm 3^\circ$, as shown in the figure:

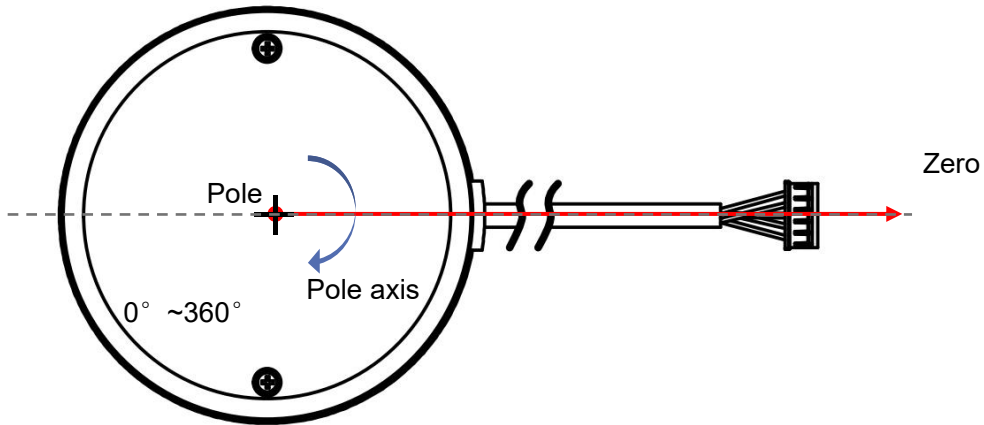

FIG 3 YDLIDAR G2 POLAR COORDINATE SYSTEM DEFINITION

Note1: When the Lidar is in production, the deviation of the assembly may cause the individual deviation of the radar zero angle of $\pm 3^\circ$

Note2: When the Lidar is assembled on the machine, the deviation of the assembly may cause slight difference in the consistency of the zero position. For the convenience of use, we provide a zero calibration software, which can customize the zero direction and assemble to the machine. The Lidar is calibrated twice. For details, please refer to the User manual.

2.7 Others

CHART 6 YDLIDAR G2 OTHERS

Item	Min	Typical	Max	Unit	Remarks
Operating temperature	0	20	50	°C	Long-term working in a high temperature environment will reduce the life span
Storage temperature	-10	/	60	°C	/
Lighting environment	0	2000	40000	Lux	For reference only
weight	/	185	/	g	N.W.

3 REVISE

Date	Version	Content
2019-09-03	1.0	Compose a first draft
2020-01-07	1.1	Optimize the presentation of application scenarios and adjust the accuracy
2020-11-18	1.2	Correct the Startup current value
2021-06-23	1.3	Modify current, temperature, power and other relevant parameters